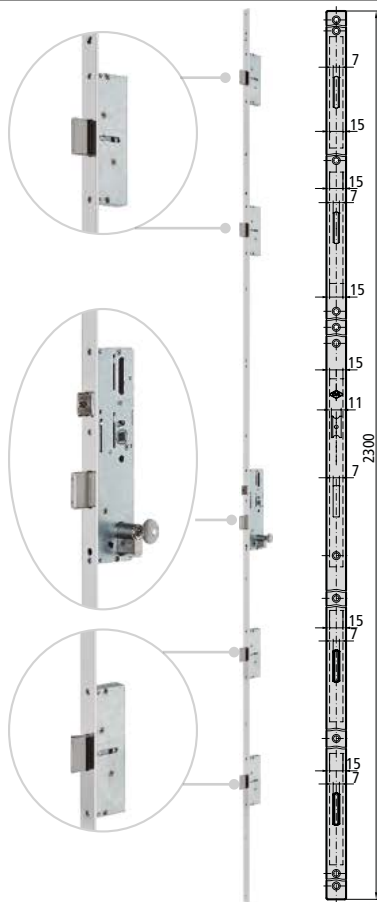

SWING DOORS / PIVOT DOORS
SLIDING DEAD BOLT MULTIPOINT LOCK, 92mm BETWEEN AXES
4E25 RANGE Soft

CHARACTERISTIC

- Maximum softness by means of gear mechanism
- 5 points lock with 22mm SS flat front plate
- 2300mm long front plate
- 11mm reversible and adjustable latch bolt
- Up and down points with sliding dead bolt
- Minimum stock: 3 versions in 1 lock (latch bolt/ roller/ dead bolt only)
- Sliding dead bolt
- Designed according to EN12209 and pr. EN15685
- Compatible with lon/DIN or short cam cylinders
- 15mm closed box
- 8mm square ruler
- Cylinder set screw

VERSIONS

- Coupling kit and additional closing point
- Rollet kit to replace latch bolt (ref. CV1E5)

OPTIONAL ACCESSORIES

- Complete range of **strike plates**
- Complete range of **cylinders**

| DESCRIPTION | REF. | MEASUREMENTS | | CAM | FINISH | | UNITS |
|-------------|------|--------------|---|-----|-------------|----------|-------|
| | | B | A | | FRONT PLATE | CYLINDER | |

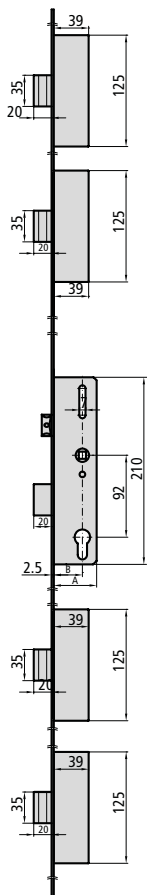

- Latch bolt and dead bolt
- Cylinder not included

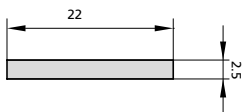

| | | | | | |
|------------|----|----|----------|----|---|
| 4E25/30/6L | 27 | 43 | 15/13,25 | Al | 1 |
| 4E25/35/6L | 32 | 48 | 15/13,25 | Al | 1 |
| 4E25/40/6L | 37 | 53 | 15/13,25 | Al | 1 |
| 4E25/45/6L | 42 | 58 | 15/13,25 | Al | 1 |
| 4E25/50/6L | 47 | 63 | 15/13,25 | Al | 1 |